



Revision History

Date	Revision	Description
2023.07.31	1.0	First Released

Table of Contents

1. Product Overview.....	4
1.1 Introduction.....	4
1.2 Feature.....	4
1.3 Product Appearance & Models.....	5
2. Product Specifications.....	6
2.1 General Specifications.....	6
2.2 Performance.....	6
2.3 Electronic Specifications.....	7
2.3.1 Block Diagram.....	7
2.3.2 Pin Assignment.....	7-9
2.4 Environmental Specifications.....	9
2.5 Mechanical Specifications.....	9
3. Supported Command.....	10
3.1 List of Command Sets.....	10
4. Part No. Decoder.....	11
4.1 Part No. Decoder.....	11~12

1. Product Overview

1.1 Introduction

Cervoz Industrial M.2 2230 Embedded Module T425 family is a Solid State Flash Disk product that is in compliance with the M.2 and PCIe Gen3x2 standards. M.2 2230 T425 family fits in any M.2 2230 (A+E) sockets in a PC or motherboard; it can be used for both booting and storage purposes.

T425 family uses SSD grade quality 3D TLC flash memory from the industry leading manufacturer Micron. Cervoz's firmware builds in a powerful ECC algorithm call Low-Density Parity Check (LDPC) decoding to improve data reliability.

T425 family offers stable performance and reliability; the product family is an ideal choice for an ultra-compact fanless PC that demands exceptional computational capabilities. Moreover, it offers an effective solution for expanding storage capacity when storage falls short.

1.2 Feature

- Compliant with PCIe Gen3x2 interface (backward compatible to PCIe Gen 1)
- Compliance:
 - NVMe 1.3
 - PCI Express Base 3.1
- 3D TLC flash memory
- Capacity: 64GB/128GB/512GB
- End-to-End data protection
- SLC write cache technology
- Thermal throttling
- Operating as boot disk
- Static and dynamic wear leveling
- Bad block management
- S.M.A.R.T. & TRIM command
- Power Saving Modes:
 - Support APST
 - Support ASPM
 - Support L1.2
- Fully compatible with Windows 8.1, Windows 10, Mac OS, and Linux*
- RoHS compliant

*Microsoft recommends when use the M.2 NVMe SSD the driver for windows 8.1 and above is required.

Mac and Linux system users need to make sure whether there is a driver support M.2 NVMe SSD or not.

1.3 Product Appearance & Models

Cervoz Industrial M.2 2230 Module T425

Standard Temperature



T425 Family Standard Temp. (0°C ~ 70°C) Model No.	Capacity
CIE-M3T425MLF064GS	64GB
CIE-M3T425MMF128GS	128GB
CIE-M3T425MOF512GS	512GB

Please Note:

Since certain storage capacity has to be reserved for firmware and controller management purposes; the physical capacity of the flash module will be approximately 93.1% of the indicated capacity. If you need to install an image that has the exact (or close to) the indicated size of the flash module, please choose your flash module with a greater capacity.

2. Product Specifications

2.1 General Specifications

Form Factor	M.2 PCIe 2230
Interface	PCIe Gen3x2 (backward compatible to PCIe Gen 1)
Connector	M.2 2230 (A+E)
NAND Flash Type	3D TLC
Capacity	64GB/128GB/512GB
Sequential Read	up to 815MB/s
Sequential Write	up to 760MB/s
ECC Scheme	Applies the LDPC (Low Density Parity Check) of ECC algorithm
MTBF	>3,000,000 hours
TeraByte Written (TBW)	64GB : 109 128GB : 219 512GB : 875
Supply Voltage	3.3V DC +/-5%
Power Consumption	Active mode: < 2500mW Idle mode: < 530mW
Dimension (LxWxH)	30.00*22.00*3.50mm

2.2 Performance

The performance was measured with below PC configuration:

- Platform: Intel NUC i7-1165G7
- RAM: Cervoz CIR-S4SUSA3232G (DDR4 4G 3200MHz)
- Operation Systems: Win10 64bit
- Testing Utility: Crystal Disk Mark v8.0.4 x64 and IOMeter, 1GB range
- PCIe Gen3 performance

Capacity	64GB	128GB	512GB
Sequential Read (Q32T1)	495MB/s	810MB/s	815MB/s
Sequential Write (Q32T1)	110MB/s	515MB/s	760MB/s
4KB Random Read (Q128T16)	30K IOPS	50K IOPS	120K IOPS
4KB Random Write (Q128T16)	30K IOPS	100K IOPS	120K IOPS

Actual performance might differ based on different using conditions and environment.

2.3 Electronic Specifications

2.3.1 Block Diagram

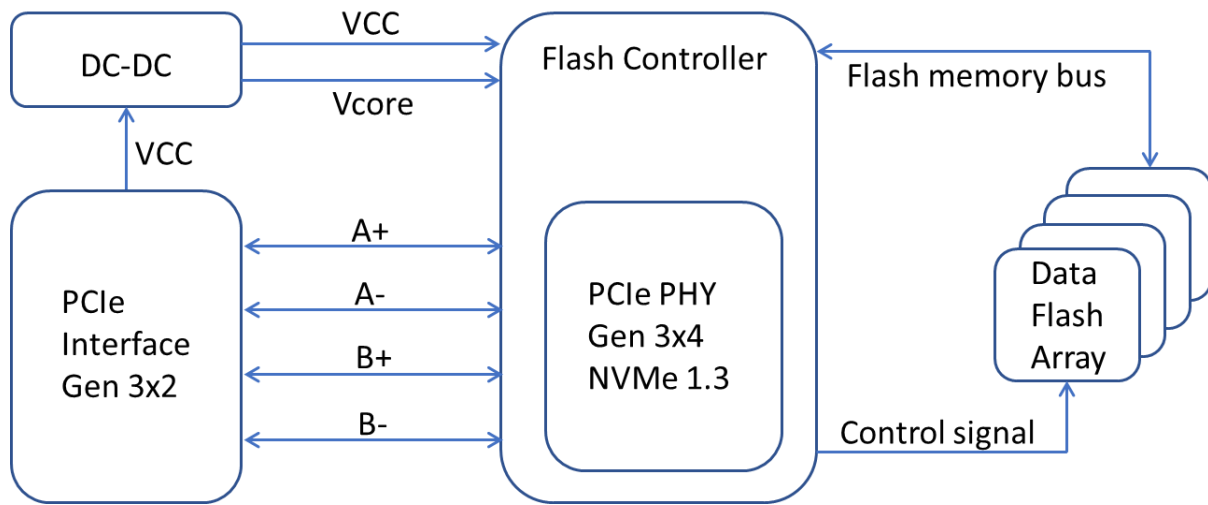

2.3.2 Pin Assignment

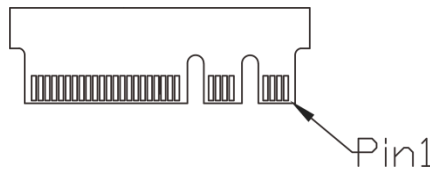

Pin #	Pin Description	Signal Name	Pin #	Pin Description	Signal Name
1	Ground	GND	15	Module Key	Key
2	3.3V power in	+3.3V	16	Not Used	NC
3	Not Used	NC	17	Not Used	NC
4	3.3V power in	+3.3V	18	Ground	GND
5	Not Used	NC	19	Not Used	NC
6	Not Used	NC	20	Not Used	NC
7	Ground	GND	21	Not Used	NC
8	Module Key	Key	22	Not Used	NC
9	Module Key	Key	23	Not Used	NC
10	Module Key	Key	24	Module Key	Key
11	Module Key	Key	25	Module Key	Key
12	Module Key	Key	26	Module Key	Key
13	Module Key	Key	27	Module Key	Key
14	Module Key	Key	28	Module Key	Key

Pin #	Pin Description	Signal Name	Pin #	Pin Description	Signal Name
29	Module Key	Key	45	Ground	GND
30	Module Key	Key	46	Not Used	NC
31	Module Key	Key	47	PCIe Reference Clock signals (100 MHz) defined by the PCI Express M.2 spec.	REFCLKp
32	Not Used	NC	48	Not Used	NC
33	Ground	GND	49	PCIe Reference Clock signals (100 MHz) defined by the PCI Express M.2 spec.	REFCLKn
34	Not Used	NC	50	Not Used	NC
35	PCIe RX Differential signal defined by the PCI Express M.2 spec	PERp0	51	Ground	GND
36	Not Used	NC	52	PE-Reset is a functional reset to the card as defined by the PCIe Mini CEM specification.	PERST#(I)(O/3.3V)
37	PCIe RX Differential signal defined by the PCI Express M.2 spec	PERn0	53	Clock Request is a reference clock request signal as defined by the PCIe Mini CEM specification; Also used by L1 PM Substates.	CLKREQ#(I/O)(O/3.3V)
38	Not Used	NC	54	Not Used	NC
39	Ground	GND	55	Not Used	NC
40	Not Used	NC	56	Not Used	NC
41	PCIe TX Differential signal defined by the PCI Express M.2 spec	PETp0	57	Ground	GND
42	Not Used	NC	58	Not Used	NC
43	PCIe TX Differential signal defined by the PCI Express M.2 spec	PETn0	59	PCIe RX Differential signal defined by the PCI Express M.2 spec	PERp1
44	Not Used	NC	60	Not Used	NC

Pin #	Pin Description	Signal Name	Pin #	Pin Description	Signal Name
61	PCIe RX Differential signal defined by the PCI Express M.2 spec	PERn1	69	Ground	GND
62	Not Used	NC	70	Not Used	NC
63	Ground	GND	71	Not Used	NC
64	Not Used	NC	72	3.3V power in	+3.3V
65	PCIe TX Differential signal defined by the PCI Express M.2 spec	PETp1	73	Not Used	NC
66	Not Used	NC	74	3.3V power in	+3.3V
67	PCIe TX Differential signal defined by the PCI Express M.2 spec	PETn1	75	Ground	GND
68	Not Used	NC			

2.4 Environmental Specifications

Type		Value
Temperature	Standard Temperature Operating:	0°C~70°C
	Standard Temperature Storage:	-40°C~85°C
Humidity	Operating & Storage	10~95%, Non-Condensing
Vibration	Non-Operating	20G, 10Hz~2000Hz
Shock	Non-Operating	1500G, 0.5ms

2.5 Mechanical Specifications

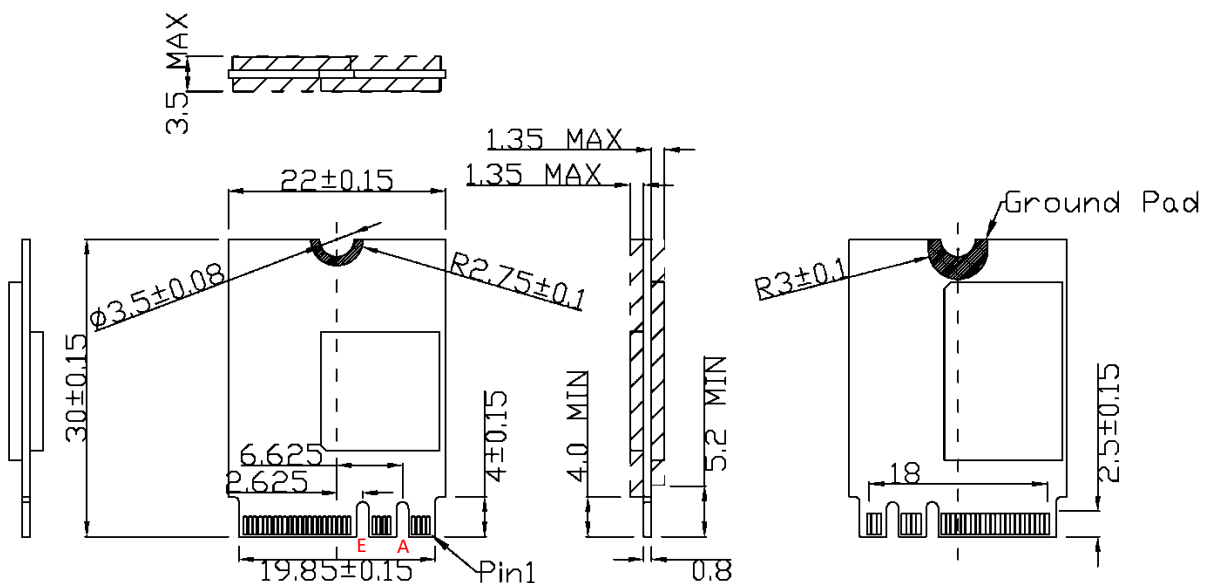

3. Supported Command

3.1 List of Command Sets

Admin Commands	
Code	Description
00h	Delete I/O Submission Queue
01h	Create I/O Submission Queue
02h	Get Log Page
04h	Delete I/O Completion Queue
05h	Create I/O Completion Queue
06h	Identify
08h	Abort
09h	Set Features
0Ah	Get Features
0Ch	Asynchronous Event Request
10h	Firmware Activate
11h	Firmware Image Download
Admin Commands – NVM Command Set Specific	
Code	Description
80h	Format NVM
81h	Security Send
82h	Security Receive
NVM Commands	
Code	Description
00h	Flush
01h	Write
02h	Read
04h	Write Uncorrectable
08h	Write Zeroes
09h	Dataset Management

4. Part No. Decoder

4.1 Part No. Decoder

1	-	2	3	4	5	6	7	8	9
Product Line	-	Form Factor	Product Series	Cervoz Family Code (Bus / Internal Control)	NAND Flash	Flash Capacity	Flash Mode	Module Capacity	Operating Temp.
XXX	-	XX	X	XXX	X	X	X	XXXX	X

1. Product Line

CIS	Cervoz Industrial SSD
CIM	Cervoz Industrial Memory Card
CIE	Cervoz Industrial Embedded Module

2. Form Factor

2S	2.5" SATA
2P	2.5" PATA
CF	CompactFlash
CA	CFast
MS	mSATA
HM	Half Size mSATA
HS	Half Slim
M3	M.2 2230
M4	M.2 2242
M6	M.2 2260
M8	M.2 2280
0V	PATA Disk 40pin Vertical
4V	PATA Disk 44pin Vertical
4L	PATA Disk 44pin Horizontal Left
7T	SATA Disk 7pin Vertical Tall
7S	SATA Disk 7pin Vertical Short
7L	SATA Disk 7pin Horizontal Left
7R	SATA Disk 7pin Horizontal Right

3. Product Series

S	Supreme Series (SLC)
R	Reliance Series (RO-MLC)
M	Momentum Series (MLC)
T	Titan Series (TLC)

4. Cervoz Family Code

Bus and Internal Control for Cervoz Product Families

5. NAND Flash

M	Micron
K	Kioxia
O	OEM NAND Flash

6. Flash Capacity

A	256Mb
B	512Mb
C	1Gb
D	2Gb
E	4Gb
F	8Gb
G	16Gb
H	32Gb
I	64Gb
J	128Gb
K	256Gb
L	512Gb
M	1Tb
N	2Tb
O	4Tb

7. Flash Mode

Internal Control for Flash Mode

8. Module Capacity

128M	128MB
256M	256MB
512M	512MB
001G	1GB
002G	2GB
004G	4GB
008G	8GB
016G	16GB
032G	32GB
064G	64GB
120G	120GB
128G	128GB
240G	240GB
256G	256GB
480G	480GB
512G	512GB
960G	960GB
001T	1TB
1920	1.92TB
002T	2TB

9. Operating Temperature

S	Standard Grade (0~ +70°C)
W	Wide Temperature Grade (-40 ~ +85°C)